

## Features of the Jergens Zero-Point Mounting System

- Positioning and clamping in one operation
- High repeatability and accuracy
- Low cost solution for quick pallet changing



Typical applications for the Jergens Zero-Point System:

- Milling
- Assembly
- Welding
- Injection Molding
- Grinding
- Measuring

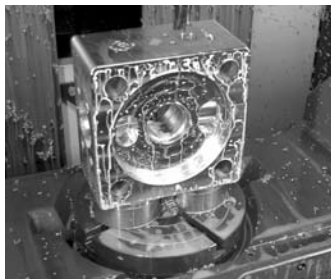

Pull Studs can also be installed directly into the workpieces, making 5-sided processing possible.

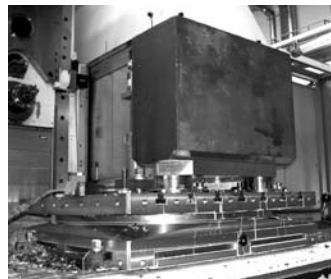

Best results with large and heavy workpieces.



Jergens Zero-Point clamping systems are made exclusively of rust-free materials and so are ideally suited for use in the food-service area as well as in the pharmaceutical and chemical industry.

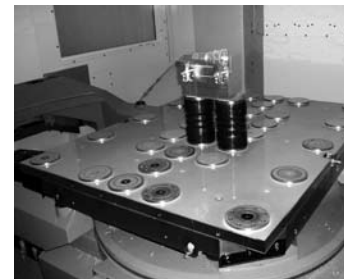

Through different dimensions, the advantage of the Zero-Point clamping system are optimally used.

## Pull Studs and Engagement Screws

Pages 1.42-1.43



## Clamping Plates with Built-In Modules

Pages 1.40-1.41

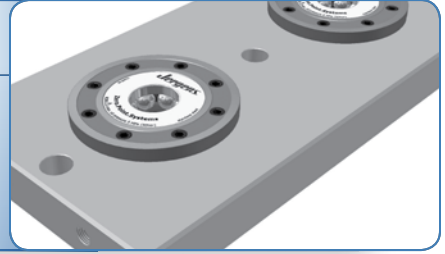

## Threaded Clamping Modules

Pages 1.44-1.45

- Machine tables
- Plates
- 4-axis/5-axis machining
- Columns
- Pallets

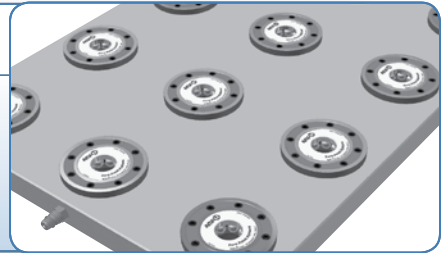
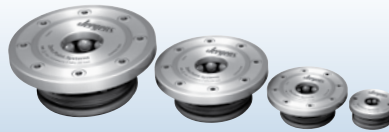

## Raised/Mounted Clamping Modules

Pages 1.46-1.47

- For large & heavy workpieces
- Pull Studs installed directly into workpiece

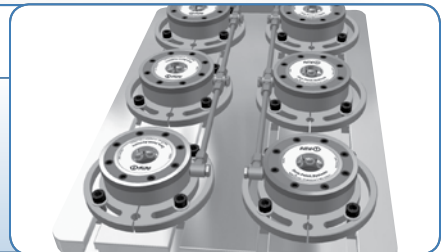
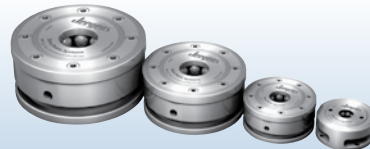

## Flange Type Module

Page 1.49

- Used to fasten surface-mounted clamping modules on the machine table
- Hydraulic release with or without blowout



## Horizontal Rapid-Clamping Module

Page 1.50

- For easy handling of heavy fixtures



## Jergens' Zero-Point Mounting System – Cut Set-up Times by Up to 90%.

Fix, Position and Clamp in a Single Step with Jergens' Zero-Point Mounting System.

Jergens is proud to introduce the best-engineered Zero-Point Mounting System (ZPS) on the market. This revolutionary technology cuts set-up time by up to 90% by combining fixing, positioning and clamping in a single operation. Available with either pneumatic or hydraulic release, these positive locking locating modules allow operators to quickly change out large and small machine fixtures with extreme accuracy and minimal effort. Other features include:

- Repeatability <0.005mm (0.0002")
- Minimizes set-up time
- Hardened stainless (AISI 440B) steel construction
- Integrated safety system
- Compact design
- Positive locking
- High retaining force

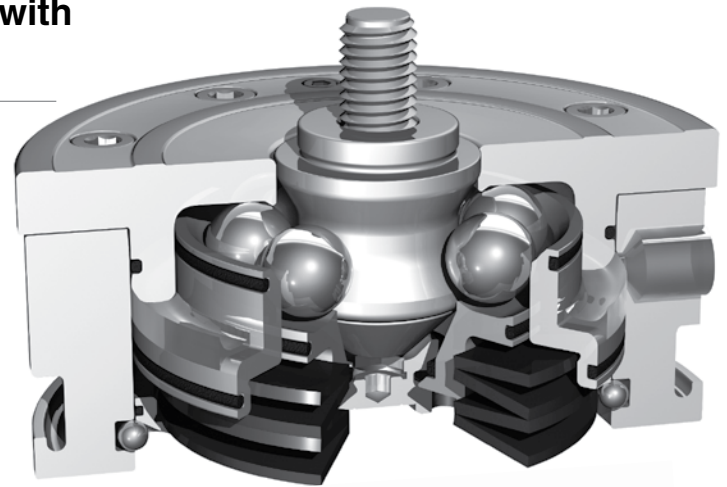

### Smart Features for Process Improvement

Reduce set-up times and increase both accuracy and repeatability with design features exclusive to the Jergens ZPS:

#### Self Guiding

The self-guiding, tapered profile of the mounting stud allows heavy plates to be installed more easily.

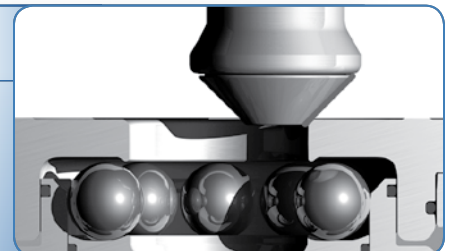

#### Alignment

Unique design eliminates the need for perfect lifts on entry and exit.

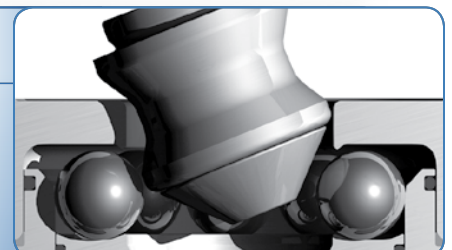

## Mechanical Locking System

Experience high holding force without the need to maintain hydraulic pressure.

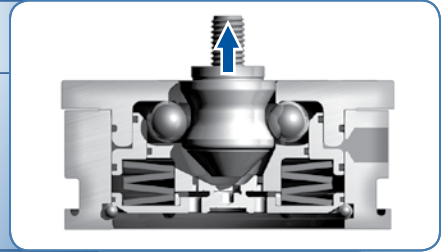

## Large Ball Diameter

Provides increased strength and even load distribution.

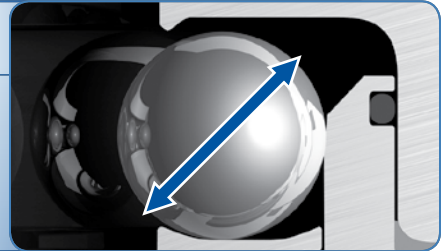

## No Ball Cage

Free movement of the bearing balls reduces friction.



## Form Fit Ball Channel

Tapered contact areas eliminate point loads and reduce failures.

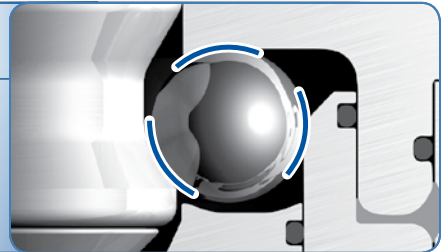

## Three-Point Load Distribution

Equal load spacing optimizes force distribution.



## Integrated Safety System

Process-sure clamping module can always be opened, eliminating the need to forcibly remove modules if a failure should occur.



## Clamping and Positioning

On each fixture use:

- 1 - Zero-Point Pull Stud
- 1 - Timing Pull Stud
- The Zero-Point and Timing Stud should be perpendicular
- Use any combination of clearance and/or protection Pull Stud

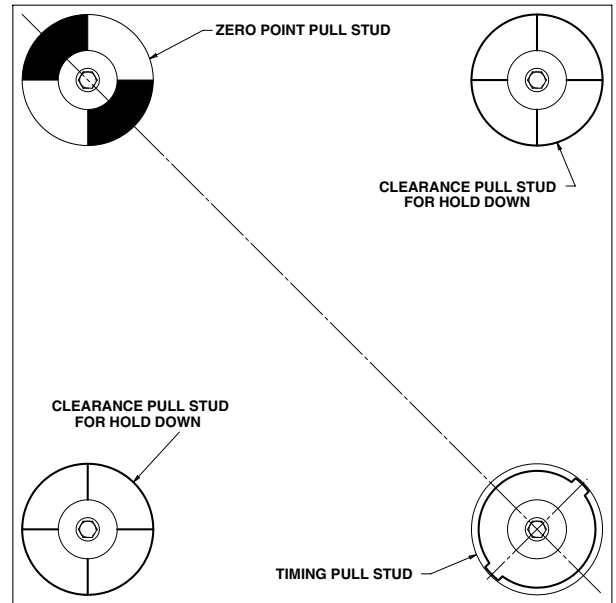

## Dimensions for machining pull stud mountings

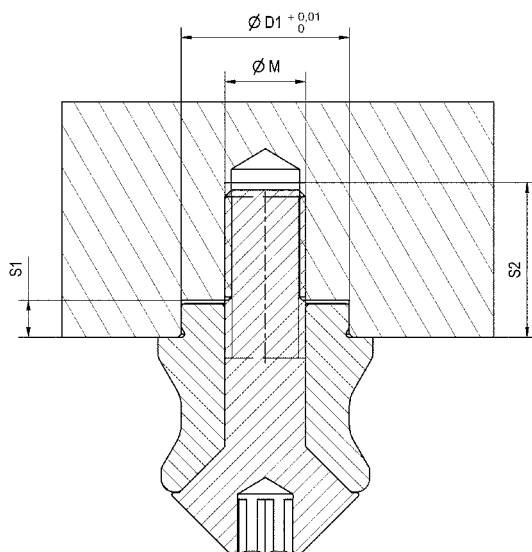

Size	$\varnothing D1$	$\varnothing M$	S1	S2
K5	10	M6	2.5	12
K10	15	M8	3.5	16
K20	25	M12	5.5	23
K40	25	M16	5.5	30

**Note:**

- Pull Stud with internal thread for clamping from above
- Pull Studs with different diameter D1, preventing interchange of the Zero-Point, timing and clearance Pull Stud during installation.
- Pull Stud for series production, (notch type), Floating Pull Stud for compensation of thermal expansion
- Automatic lifting of the pallet / fixture

**Figure:**

Shown with Pull Stud and engagement screw

## 2-Way Clamping Station

Hydraulic Unlocking

Repeatability < 0.005 mm (0.0002")

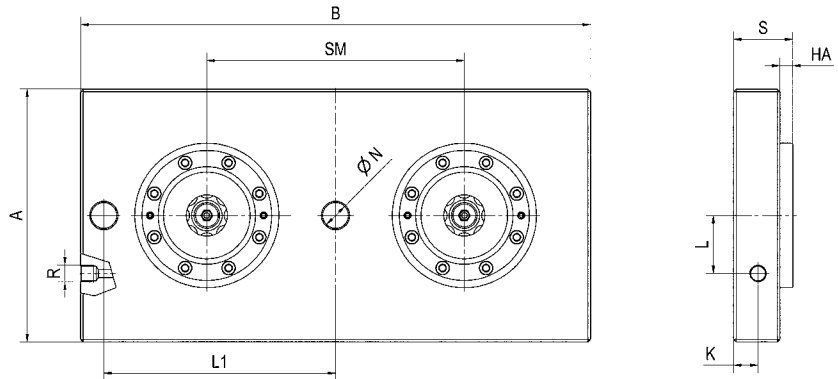
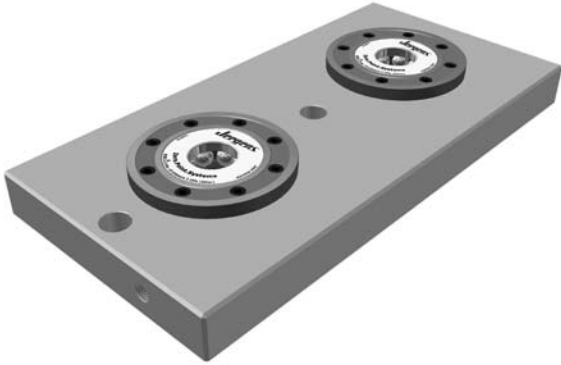

Part Number	Size	Pull-In/Locking Force up to kN / (lbs)	A	B	HA	K	L	L1	ØN	R	S	SM	kg
303289	20	2 x 20 / (2 x 4500)	196	396	10	19	45	180	20	G1/4	46	200	21.9
303297	40	2 x 40 / (2 x 9000)	296	546	15	26	57	250	25	G1/4	61	320	59.5

All linear dimensions in (mm)

Note: On request, we can incorporate mounting holes to your requirements in the base plate. Other dimensions, gauges and number of clamping module layouts on

## 4-way clamping Station

Hydraulic Unlocking

Repeatability < 0.005 mm (0.0002")

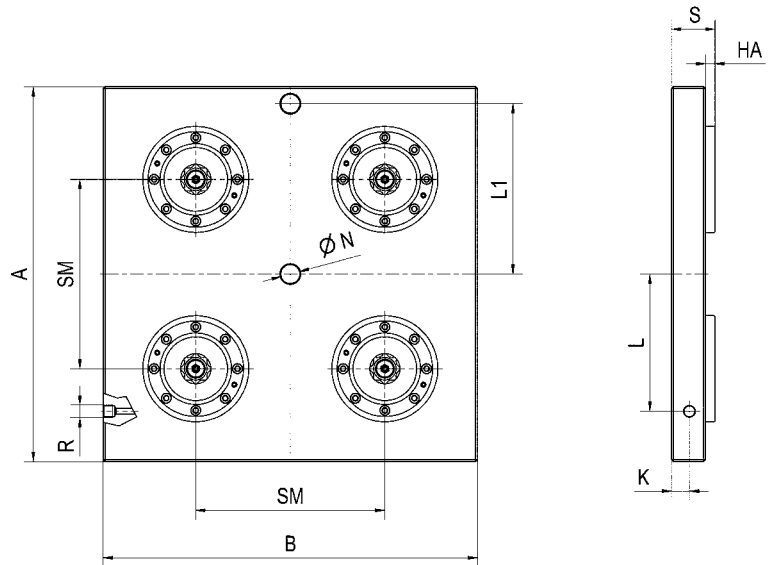
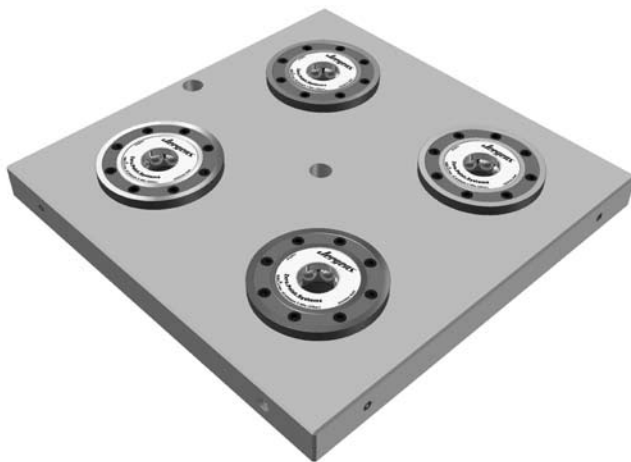

Part Number	Size	Pull-In/Locking Force up to kN / (lbs)	A	B	HA	K	L	L1	ØN	R	S	SM	kg
303321	20	4 x 20 / (4 x 4500)	396	396	10	18	148	180	20	G1/4	46	200	44.0
303339	40	4 x 40 / (4 x 9000)	546	546	15	26	217	250	25	G1/4	61	320	110.0

All linear dimensions in (mm)

Note: On request, we can incorporate mounting holes to your requirements in the base plate. Other dimensions, gauges and number of clamping module layouts on request.

## Pull Studs

### K5 Modules

Hardened Stainless Steel, for hydraulic and pneumatic clamping modules

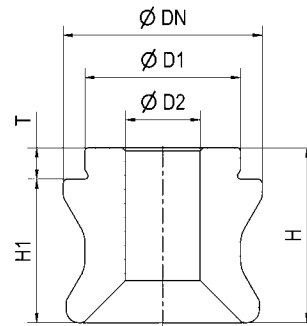

Zero Point Timing Clearance

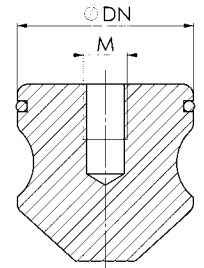

Protection Pull Stud

Part Number	Size	Description	ØDN	ØD1	ØD2	H	H1	M	T	g
306019	K5	Zero-Point Stud	15.0	10	6	12.7	10.2	-	2.5	15
306035	K5	Timing Stud	15.0	10	6	12.7	10.2	-	2.5	15
306050	K5	Clearance Stud	15.0	10	6	12.7	10.2	-	2.5	15
306076	K5	Protection Plug	14.8	-	-	10.2	-	M 6	8.0	12

### K10 Modules

Hardened Stainless Steel, for hydraulic and pneumatic clamping modules

Part Number	Size	Description	ØDN	ØD1	ØD2	H	H1	M	T	g
303610	K10	Zero-Point Stud	22.0	15	8	19	16	-	3	30
303636	K10	Timing Stud	22.0	15	8	19	16	-	3	30
304519	K10	Clearance Stud	22.0	15	8	19	16	-	3	30
304535	K10	Protection Plug	21.8	-	-	16	-	M 8	12	30

### K20 Modules

Hardened Stainless Steel, for hydraulic and pneumatic clamping modules

Part Number	Size	Description	ØDN	ØD1	ØD2	H	H1	M	T	g
303149	K20	Zero-Point Stud	32.0	25	12	28	23	-	5	110
303156	K20	Timing Stud	32.0	25	12	28	23	-	5	110
303164	K20	Clearance Stud	32.0	25	12	28	23	-	5	110
303172	K20	Protection Plug	31.8	-	-	23	-	M8	16	110

### K40 Modules

Hardened Stainless Steel, for hydraulic and pneumatic clamping modules

Part Number	Size	Description	ØDN	ØD1	ØD2	H	H1	M	T	g
303180	K40	Zero-Point Stud	40.0	25	16	34	29	-	5	180
303198	K40	Timing Stud	40.0	25	16	34	29	-	5	180
303206	K40	Clearance Stud	40.0	25	16	34	29	-	5	180
303214	K40	Protection Plug	39.8	-	-	29	-	M8	20	180

## Engagement Screws

Strength class 10.9

For installation and surface mounted clamping modules

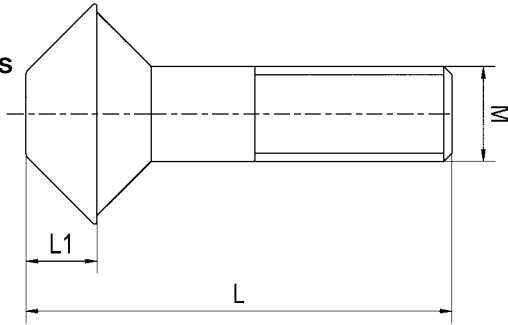

Part Number	Size	M	L	L1	g
306092	K 5	M 6	25	3.4	18
303578	K10	M 8	37	6.0	30
303222	K20	M12	54	9.0	70
303230	K40	M16	69	10.0	130

## Horizontal Engagement Screws

Strength class 10.9

For horizontal rapid clamping cylinder on page 1.46

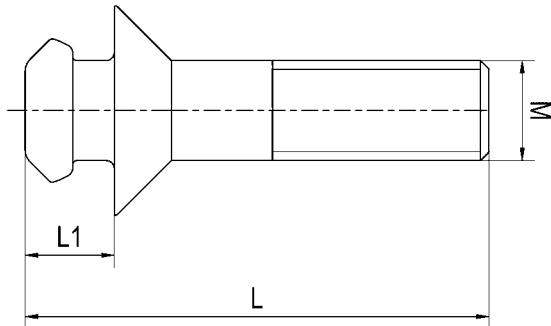

Part Number	Size	M	L	L1	g
303248	K20	M12	56	10.5	100
303255	K40	M16	73	13.0	200

## Threaded Clamping Modules (K5)

Round, Screw-In Version

Hydraulic Unlocking

Cover and piston hardened.

Repeatability < 0.005 mm (0.0002")



With a small footprint for installation in base plates, machine tables, clamping profiles, columns and towers, swivel bridges, machine pallets and clamping pallets.

- Installation diagrams on request

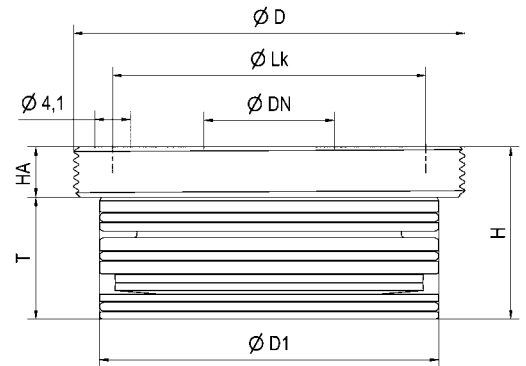

### Hardened Stainless Steel

Part Number	Size	Pull-In/Locking Force up to kN / (lbs)	Holding Force kN / (lbs)	ØD	ØDN	ØD1	H	HA	ØLK	T	g
305953	K5	5 / (1100)	13 / (2900)	M45 x 1	15	39	19.8	5.8	36	14	300

All linear dimensions in (mm)

Note: Threaded clamping module with a low installation height of 19.8 mm and an installation diameter of 45 mm (M45 x 1).

Hydraulic supply and pressure is only needed for unclamping (min. 50 bar / 725psi, max. 60 bar / 870psi). The threaded clamping module is mechanically locked in the clamped position. The unique mechanical locking system results in virtually no vibration even with extensive machining forces. Further more, there are no cumbersome lines or dangers of leakage. The contact surface is the upper surface of the housing. The hydraulic design has 1 connection: 1 x unclamping

## Round, Screw-in Version

Pneumatic Unlocking

Cover and piston hardened.

Repeatability < 0.005 mm (0.0002")



With a small footprint for installation in base plates, machine tables, clamping profiles, columns and towers, swivel bridges, machine pallets and clamping pallets. Pneumatic modules are optimally suited for use in the food, pharmaceutical and chemical industries, as well as in oil-free applications.

- Installation diagrams on request

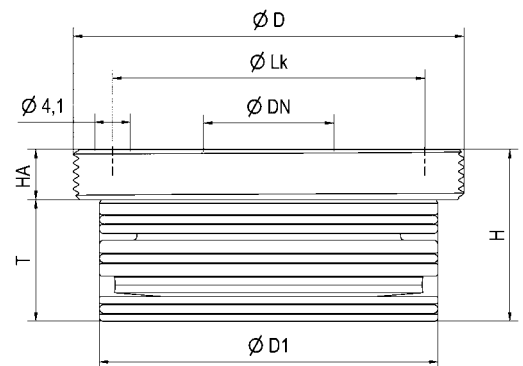

### Hardened Stainless Steel

Part Number	Size	Pull-In/Locking Force up to kN / (lbs)	Holding Force kN / (lbs)	ØD	ØDN	ØD1	H	HA	ØLK	T	g
305979	K5	1.5 / (330)	13 / (2900)	M45 x 1	15	39	19.8	5.8	36	14	300

All linear dimensions in (mm)

Note: Threaded clamping module with a low installation height of 19.8 mm and an installation diameter of 45 mm (M45 x 1).

Pneumatic pressure is needed for unclamping ( min 8 bar/ 116 psi, max 12 bar/ 175 psi). For clamping process pneumatic pressure of min 5 bar / 75 psi, max 6 bar / 90 psi is required briefly in order to achieve defined pull-in force. The threaded clamping module is mechanically locked in the clamped position. The unique mechanical locking system results in virtually no vibration even with extensive machining forces. Further more, there are no cumbersome lines or dangers of leakage. The pneumatic design has 2 connections: 1 x unclamping / 1 x clamping.

## Threaded Clamping Modules (K10, K20, K40)

### Round, Hydraulic Unlocking

Cover and piston hardened.

Repeatability < 0.005 mm (0.0002")



With a small foot-print for installation in base plates, machine tables, clamping profiles, columns and towers, swivel bridges, machine pallets and clamping pallets.

- Installation diagrams on request

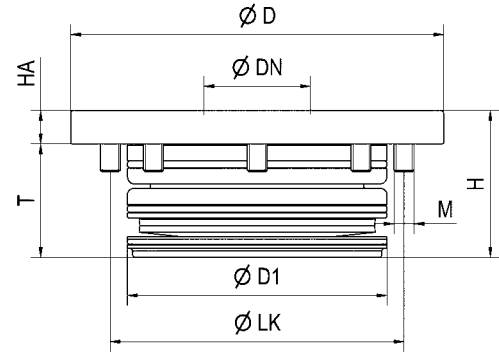

### Hardened Stainless Steel

Part Number	Size	Pull-in/locking force up to kN / (lbs)	Holding force kN / (lbs)	Blow out	ØD	ØDN	ØD1	H	HA	ØLK	M	T	kg
303628	K10	10 / (2250)	25 / (5620)	-	78	22	50	30	7	60	M5	23	0.45
305367	K10	10 / (2250)	25 / (5620)	Yes	78	22	50	30	7	60	M5	23	0.45
302984	K20	20 / (4500)	55 / (12350)	-	112	32	78	44	10	88	M6	34	1.40
302992	K20	20 / (4500)	55 / (12350)	Yes	112	32	78	44	10	88	M6	34	1.40
303024	K40	40 / (9000)	105 / (23600)	-	148	40	102	57	15	118	M8	42	3.45
303032	K40	40 / (9000)	105 / (23600)	Yes	148	40	102	57	15	118	M8	42	3.40

All linear dimensions in (mm)

**Note:** Threaded installation clamping modules have high holding and pull-in forces with very small installation dimensions.

Hydraulic supply and pressure is only needed for unclamping (min. 50 bar / 725psi, max. 60 bar / 870psi). The threaded clamping module is mechanically locked in the clamped position. The unique mechanical locking system results in virtually no vibration even with extensive machining forces. Further more, there are no cumbersome lines or dangers of leakage. The contact surface is the upper surface of the housing. The hydraulic design has 1 connection: 1 x unclamping

## Pneumatic Unlocking

Cover and piston hardened.

Repeatability < 0.005 mm (0.0002")



With a small footprint for installation in base plates, machine tables, clamping profiles, columns and towers, swivel bridges, machine pallets and clamping pallets.

- Installation diagrams on request

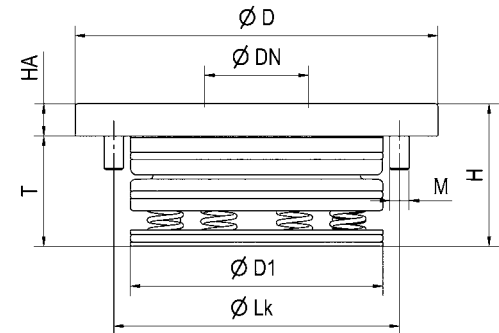

### Hardened Stainless Steel

Part Number	Size	Pull-In/Locking force up to kN / (lbs)	Holding Force kN / (lbs)	Blow out	ØD	ØDN	ØD1	H	HA	ØLK	M	T	kg
303602	K10	8 / (1800)	25 / (5620)	-	78	22	50	30	7	60	M5	23	0.45
305375	K10	8 / (1800)	25 / (5620)	Yes	78	22	50	30	7	60	M5	23	0.45
303008	K20	17 / (3800)	55 / (12350)	-	112	32	78	44	10	88	M6	34	1.40
303016	K20	17 / (3800)	55 / (12350)	Yes	112	32	78	44	10	88	M6	34	1.40
303040	K40	30 / (6700)	105 / (23600)	-	148	40	102	57	15	118	M8	42	3.45
303057	K40	30 / (6700)	105 / (23600)	Yes	148	40	102	57	15	118	M8	42	3.40

All linear dimensions in (mm)

**Note:** The installation clamping modules have high holding and pull-in forces with very small installation dimensions.

Pneumatic pressure is needed for unclamping (min 8 bar/116 psi, max 12 bar/175 psi). For clamping process pneumatic pressure of min 5 bar / 75 psi, max 6 bar / 90 psi is required briefly in order to achieve defined pull-in force. The installation clamping module is mechanically locked in the clamped position. The unique mechanical locking system results in virtually no vibration even with extensive machining forces. Further more, there are no cumbersome lines or dangers of leakage. The pneumatic design has 2 connections: 1 x unclamping / 1 x clamping.

## Raised/Mounted Clamping Modules (K5)

Round, Hydraulic Unlocking

Cover and piston hardened.

Repeatability < 0.005 mm (0.0002")



For mounting on machine tables, clamping profiles, columns and towers, measuring machines, assembly stations.

- Installation diagrams on request

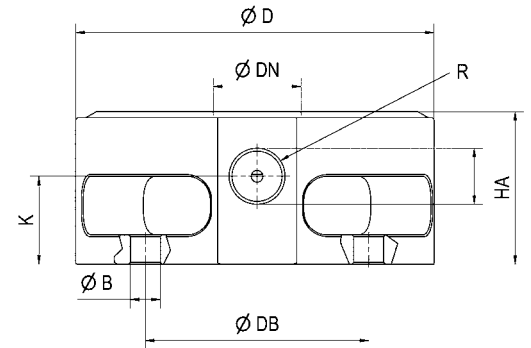

### Stainless Steel

Part Number	Size	Pull-In/Locking Force up to kN / (lbs)	Holding Force kN / (lbs)	ØB	ØD	ØDB	ØDN	HA	K	R	g
306159	K5	5 / (1100)	13 / (2900)	5.8	62	54	15	26	15	G1/8	300

All linear dimensions in (mm)

Note: Hydraulic supply and pressure is only needed for unclamping (min. 50 bar / 725psi, max. 60 bar / 870psi). The installation clamping module is mechanically locked in the clamped position. The unique mechanical locking system results in virtually no vibration even with extensive machining forces. The contact surface is the upper surface of the housing. The hydraulic design has 1 connection: 1 x unclamping

## Round, Pneumatic Unlocking

Cover and piston hardened.

Repeatability < 0.005 mm (0.0002")



For mounting on machine tables, clamping profiles, columns and towers, measuring machines, assembly stations.

- Installation diagrams on request

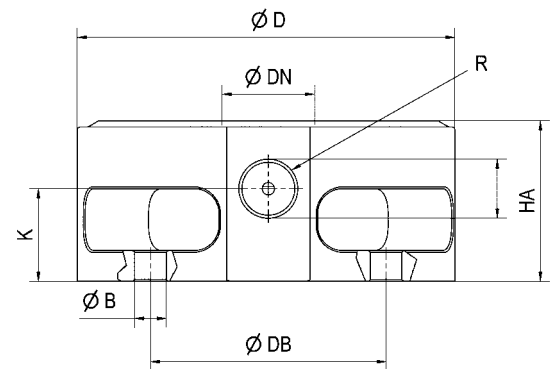

### Hardened Stainless Steel

Part Number	Size	Pull-In/Locking Force up to kN / (lbs)	Holding Force kN / (lbs)	ØB	ØD	ØDB	ØDN	HA	K	R	g
306175	K5	1.5 / (330)	13 / (2900)	5.8	62	54	15	26	15	G1/8	300

All linear dimensions in (mm)

Note: Pneumatic pressure is needed for unclamping ( min 8 bar/ 116 psi, max 12 bar/ 175 psi). For clamping process pneumatic pressure of min 5 bar / 75 psi, max 6 bar / 90 psi is required briefly in order to achieve defined pull-in force. The installation clamping module is mechanically locked in the clamped position. The unique mechanical locking system results in virtually no vibration even with extensive machining forces. The pneumatic design has 2 connections: 1 x unclamping / 1 x clamping.

## Raised/Mounted Clamping Modules (K10, K20, K40)

### Round, Hydraulic Unlocking

Cover and piston hardened.

Repeatability < 0.005 mm (0.0002")



For mounting on machine tables, clamping profiles, columns and towers, measuring machines, assembly stations in connection with clamping bracket on page 1.48.

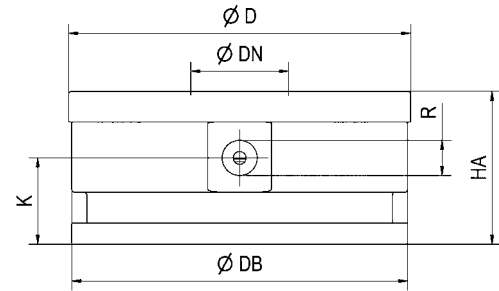

### Hardened Stainless Steel

Part Number	Size	Pull-In/Locking Force up to kN / (lbs)	Holding Force kN / (lbs)	Blow out	ØD	ØDB	ØDN	HA	K	R	kg
303487	K10	10 / (2250)	25 / (5620)	-	78	77.5	22	30	16.50	G1/8	0.90
303545	K10	10 / (2250)	25 / (5620)	Yes	78	77.5	22	30	16.50	G1/8	0.90
302828	K20	20 / (4500)	55 / (12350)	-	112	110.0	32	50	28.25	G1/4	2.75
302836	K20	20 / (4500)	55 / (12350)	Yes	112	110.0	32	50	28.25	G1/4	2.70
302869	K40	40 / (9000)	105 / (23600)	-	148	146.0	40	62	32.50	G1/4	3.85
302877	K40	40 / (9000)	105 / (23600)	Yes	148	146.0	40	62	32.50	G1/4	3.80

All linear dimensions in (mm)

Note: Hydraulic supply and pressure is only needed for unclamping (min. 50 bar / 725psi, max. 60 bar / 870psi). The installation clamping module is mechanically locked in the clamped position. The unique mechanical locking system results in virtually no vibration even with extensive machining forces. Further more, there are no cumbersome lines and no danger of leakage. The contact surface is the upper surface of the housing. The hydraulic design has 1 connection: 1 x unclamping

### Round, Pneumatic Unlocking

Cover and piston hardened.

Repeatability < 0.005 mm (0.0002")



For mounting on machine tables, clamping profiles, columns and towers, measuring machines, assembly stations in connection with clamping bracket on page 1.48.

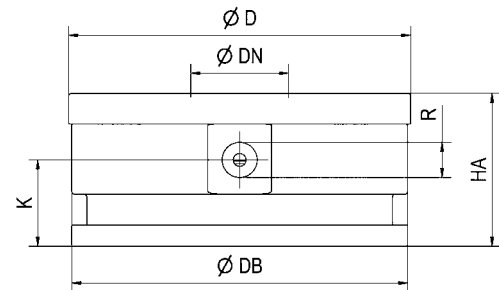

### Hardened Stainless Steel

Part Number	Size	Pull-In/Locking Force up to kN / (lbs)	Holding Force kN / (lbs)	Blow out	ØD	ØDB	ØDN	HA	K	R	kg
303529	K10	8 / (1800)	25 / (5620)	-	78	77.5	22	30	16.50	G1/8	0.90
305193	K10	8 / (1800)	25 / (5620)	Yes	78	77.5	22	30	16.50	G1/8	0.90
302844	K20	17 / (3800)	55 / (12350)	-	112	110.0	32	50	28.25	G1/4	2.60
302851	K20	17 / (3800)	55 / (12350)	Yes	112	110.0	32	50	28.25	G1/4	2.60
302885	K40	30 / (6700)	105 / (23600)	-	148	146.0	40	62	32.50	G1/4	6.45
302893	K40	30 / (6700)	105 / (23600)	Yes	148	146.0	40	62	32.50	G1/4	6.40

All linear dimensions in (mm)

Note: Pneumatic pressure is needed for unclamping (min 8 bar/ 116 psi, max 12 bar/ 175 psi). For clamping process pneumatic pressure of min 5 bar / 75 psi, max 6 bar / 90 psi is required briefly in order to achieve defined pull-in force. The installation clamping module is mechanically locked in the clamped position. The unique mechanical locking system results in virtually no vibration even with extensive machining forces. The pneumatic design has 2 connections: 1 x unclamping / 1 x clamping.

## Clamping Bracket for Raised/Mounted Clamping Modules

Black Nitrided



Clamping flanges are used to fasten raised/mounted clamping modules on the machine table. See page 1.47.

- Special clamping flanges for various T-slot tables
- Clamping flange and housing manufactured as a single piece

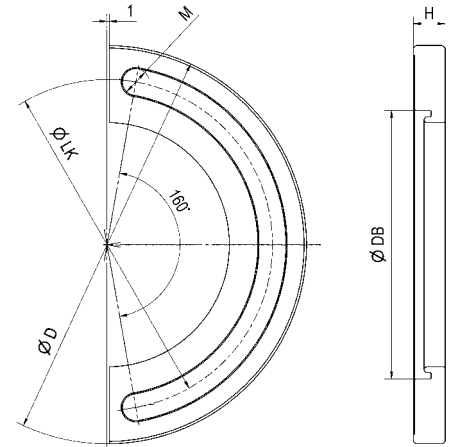

### Stainless Steel

Part Number	Size	Pieces Per Module	ØD	ØDB	H	ØLK	M	g
303495	10	2	114	77.5	7.75	94	8.5	180
302901	20	2	164	110.0	13.00	136	11.0	400
302919	40	2	202	146.0	16.00	172	13.0	550

All linear dimensions in (mm)

## Flange Type Installation Modules



#### Features:

- Oil supply by pipes or manifolds
- Integrated centering
- Provided as assembled unit

#### Benefits:

- Simple design and manufacturing of adaptor plate
- Weight saving due to less thickness for adaptor plate
- Easy to adapt to existing mounting angles and cubes

#### Installation comparison

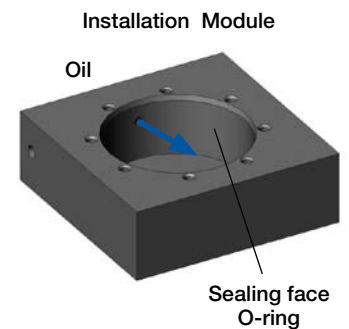
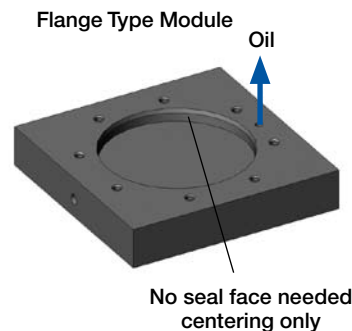
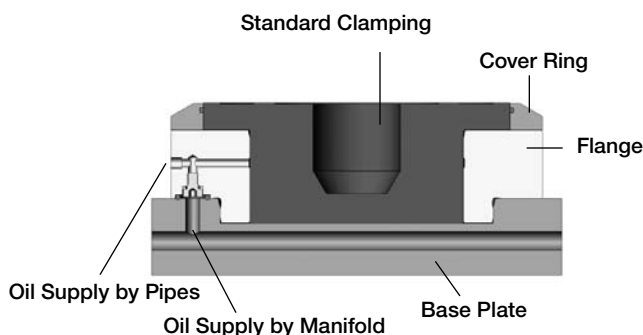

## Flange Type Installation Modules

### Hydraulic Release

Cover and piston hardened.

Repeatability < 0.005 mm (0.0002")

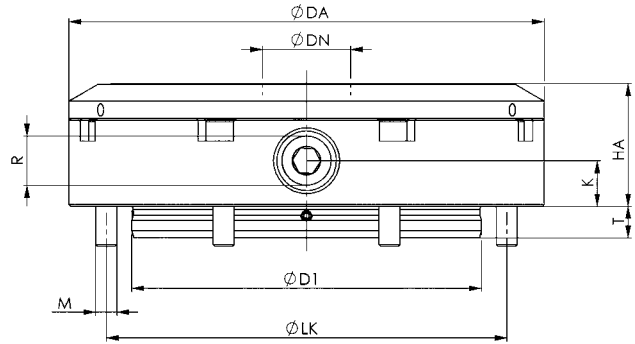

### Hardened Stainless Steel

Part Number	Size	Pull-In/Locking force up to kN / (lbs)	Holding Force kN / (lbs)	Blow out	ØDA	ØDN	ØD1	HA	K	ØLK	M	R	T	kg
424069	K10	10 / (1800)	25 / (5620)	-	100	22	67	24	9	90	M5	G1/8	5.9	1.35
424085	K10	10 / (1800)	25 / (5620)	Yes	100	22	67	24	9	90	M5	G1/8	5.9	1.35
423947	K20	20 / (3800)	55 / (12350)	-	136	32	100	35	13	124	M6	G1/8	8.9	3.75
423962	K20	20 / (3800)	55 / (12350)	Yes	136	32	100	35	13	124	M6	G1/8	8.9	3.76
424127	K40	40 / (6700)	105 / (23600)	-	180	40	120	45	15	163	M8	G1/8	11.9	4.97
424143	K40	40 / (6700)	105 / (23600)	Yes	180	40	120	45	15	163	M8	G1/8	11.9	4.97

All linear dimensions in (mm)

**Note:** Combines features of the Threaded Module and Raised/Mounted module. Especially designed when installation space is limited and base plate or angle plate has relatively thin dimensions. The positioning of the module is simple and accurate when using the precision flange diameter. Hydraulic supply is possible by manifolds or pipes/hoses. Hydraulic supply and pressure is only needed for unclamping (min. 50 bar / 725psi, max. 60 bar / 870psi). The module is mechanically locked in the clamped position. The unique mechanical locking system results in virtually no vibration even with extensive machining forces. The hydraulic design has 1 connection: 1 x unclamping

### Pneumatic Release

Cover and piston hardened.

Repeatability < 0.005 mm (0.0002")

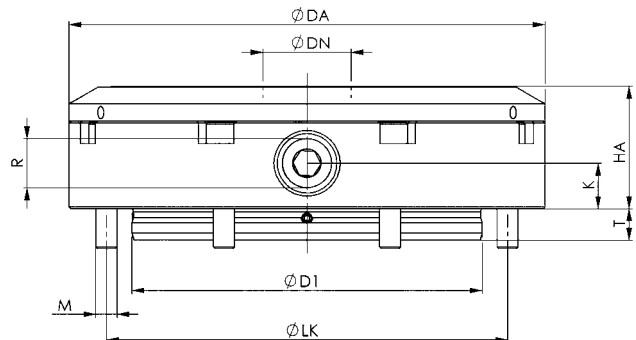

### Hardened Stainless Steel

Part Number	Size	Pull-In/Locking force up to kN / (lbs)	Holding Force kN / (lbs)	Blow out	ØDA	ØDN	ØD1	HA	K	ØLK	M	R	T	kg
424101	K10	6 / (1800)	25 / (5620)	-	100	22	67	24	9	90	M5	G1/8	5.9	1.35
423988	K20	17 / (1800)	55 / (5620)	-	136	32	100	35	13	124	M6	G1/8	8.9	4.97
424168	K40	30 / (3800)	105 / (12350)	-	180	40	120	45	15	163	M6	G1/8	11.9	4.97

All linear dimensions in (mm)

**Note:** Combines features of the Threaded Module and Raised/Mounted module. Especially designed when installation space is limited and base plate or angle plate has relatively thin dimensions. The positioning of the module is simple and accurate when using the precision flange diameter. Pneumatic supply is possible by manifolds or pipes/hoses. Pneumatic pressure is needed for unclamping (min 8 bar / 116 psi, max 12 bar / 175 psi). For clamping process pneumatic pressure of min 5 bar / 75 psi, max 6 bar / 90 psi is required briefly in order to achieve defined pull-in force. The installation clamping module is mechanically locked in the clamped position. The unique mechanical locking system results in virtually no vibration even with extensive machining forces. The pneumatic design has 2 connections: 1 x unclamping / 1 x clamping.

## Horizontal Rapid-Clamping Cylinder Hydraulic Unlocking

Cover and piston hardened.  
Repeatability < 0.005 mm (0.0002")



- For easy handling of heavy fixtures
- Makes palletization very quick by hooking into a hole at the top and moving downwards
- No searching for the holes
- No damage to Zero-Point bore or pull studs

### Hardened Stainless Steel

Part Number	Size	Pull-In/Locking Force up to kN / (lbs)	Holding Force kN / (lbs)	Blow Out	Advance Motion, Hydr. Suspension Piston	kg
303065	K20	20 / (4500)	55 / (12350)			2.1
306217	K20	20 / (4500)	55 / (12350)		Yes	2.1
303073	K20	20 / (4500)	55 / (12350)	Yes		2.1
306233	K20	20 / (4500)	55 / (12350)	Yes	Yes	2.1
303107	K40	40 / (9000)	105 / (23600)			5.2
306258	K40	40 / (9000)	105 / (23600)		Yes	5.2
303115	K40	40 / (9000)	105 / (23600)	Yes		5.2
306274	K40	40 / (9000)	105 / (23600)	Yes	Yes	5.2

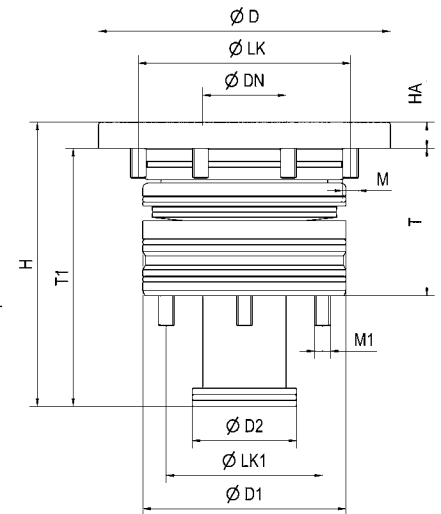

### Dimensions (mm)

Part Number	ØD	ØDN	ØD1	ØD2	H	HA	ØLK	ØLK1	M	M1	T	T1
303065	112	32	78	40	109	10	88	60	M6	M6	56.5	99
306217	112	32	78	40	109	10	88	60	M6	M6	56.5	99
303073	112	32	78	40	109	10	88	60	M6	M6	56.5	99
306233	112	32	78	40	109	10	88	60	M6	M6	56.5	99
303107	148	40	102	48	144	15	118	76	M8	M6	73	129
306258	148	40	102	48	144	15	118	76	M8	M6	73	129
303115	148	40	102	48	144	15	118	76	M8	M6	73	129
306274	148	40	102	48	144	15	118	76	M8	M6	73	129

All linear dimensions in (mm)

Note: As standard, there is a manual or hydraulic advance motion of the suspension piston.

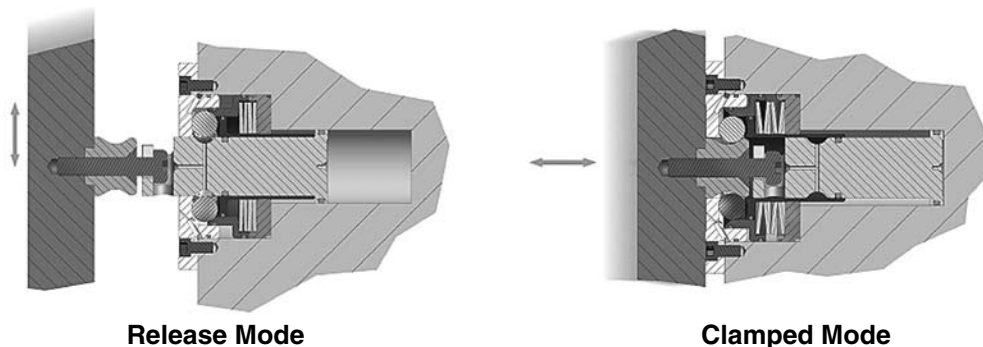

Release Mode

Clamped Mode